



## PR 6221

### Weighbridge Load Cell



#### 20t... 75t, Typ C3/C4/C5/C6

- No corner adjustment necessary
- High overload capacity
- IP 68 (1.5 m/10,000 hrs)  
IP 69K (washdown cleaning)
- Proven rocker-pin principle
- Best overvoltage protection
- Highest reliability
- 100 % Maintenance free
- Ex - version available
- Patent pending:  
WO 01/18504, EP 1 227 306 A1

#### Product Profile

The PR 6221 range of load cells is designed exclusively for use on road weighbridges. The unique design principle, combined with the installation kits, balance out movements caused by mechanical or thermal expansion or contraction of the weighbridge construction.

The unique combination of the selected geometry and material/surface hardness parameters guarantees perfect rolling characteristics, high restoring forces and long-term maintenance-free operation. A particular design characteristic is that the height and shape of the load cell remain constant over various load stages, whilst there is a particularly high overload range of, in part, up to 200%.

At the same time, this range distinguishes itself – in addition to its high measurement accuracy and repeatability – above all for its unmatched reliability, robustness and stability, which enable trouble-free operation without adjustment, year after year.

The pendulum support principle, combined with patented measuring element geometry, ensures that force transmission into the sensor is always at the optimum level and, in this way, the effect on measurement accuracy is minimized. At the same time, the load cell offers a particularly high overload range.

The hermetically sealed enclosure and special TPE cable allow the unit to be used even under extreme operating conditions.

Special resistance strain gauge technology, in combination with the PR6021/.. cable junction boxes, provides for demonstrably improved lightning protection. The entire measurement chain can be calibrated without the use of a reference weight. Due to "matched output" technology in many cases electrical corner adjustment is not required. This saves a tremendous amount of time during commissioning. An explosion-proof (Ex) version of this range of load cells is also available, as an option, for use in intrinsically safe environments.

## Technical Data

Maximum capacity	highest limit of specified measuring range	$E_{max}$	20	25	30	50	60	75	t
Max. usable load	upper limit for measurements	$E_u$	40	37.5	60	75	75	75	t
Destructive load	danger of mechanical destruction	$E_d$	>100	>75	>150	>150	>150	>150	t
Rated output	relative output signal at nominal load for accuracy classes C4 at $E_{max} \geq 60t$ , C5 at $E_{max} \geq 50t$	$C_n$	1	2	1	2	2.4	3	mV/V
							1.5	1.5	1.5
Nominal deflection	max.elastic deformation under nominal load	$s_{nom}$	0.4	0.5	0.5	0.8	0.9	1.1	mm
<b>Accuracy class</b>			<b>C3</b>	<b>C4</b>	<b>C5</b>	<b>C6*</b>			
Accuracy class			0.015	0.012	0.010	0.008	% $E_{max}$		
Minimum dead load	lowest limit of specified measuring range	$E_{min}$	0	0	0	0	% $E_{max}$		
Min.LC verification interval	minimum load cell verification interval ( $v_{min} = E_{max}/Y$ )	Y	14,000	20,000	20,000	20,000			
Deadload Return	factor for min. dead load output return (DR = $1/2 E_{max}/Z$ ) for $E_{max} 50t$ :	Z	6,000	8,000	8,000	8,000			
		Z		6,000	6,000				
Tolerance on rated output	permissible deviation from rated output	$d_c$	<0.07	<0.07	<0.07	<0.07	% $C_n$		
Zero output signal	load cell output signal under unloaded condition	$S_{min}$	< 1.0	< 1.0	< 1.0	< 1.0	% $C_n$		
Repeatability error	max.change in load cell output for repeated loading	$\epsilon_R$	< 0.005	< 0.005	< 0.005	< 0.005	% $C_n$		
Creep, during 30 min	max.change in load cell output under nominal load	$d_{cr}$	< 0.015	< 0.0125	< 0.010	< 0.008	% $C_n$		
Non-linearity	max. deviation from best straight line through zero	$d_{lin}$	< 0.01	< 0.01	< 0.01	< 0.01	% $C_n$		
Hysteresis	max. diff.in LC output between loading and unloading	$d_{hy}$	<0.0165	<0.0125	<0.010	<0.008	% $C_n$		
Temperature effect on $S_{min}$	max. change of $S_{min}/10K \Delta T$ over $B_r$ referred to $C_n$	$TK_{S_{min}}$	<0.01	<0.007	<0.007	<0.007	% $C_n/10K$		
Temperature effect on $C_n$	max. change of $C_n/10K \Delta T$ over $B_r$ referred to $C_n$	$TK_c$	<0.01	<0.008	<0.007	<0.005	% $C_n/10K$		
Input impedance	between supply terminals	$R_{LC}$	1,080 ±10	1,080 ±10	1,080 ±10	1,080 ±10	$\Omega$		
Output impedance	between measuring terminals for accuracy classes C5 at $E_{max} = 50t$ C4,C5 at $E_{max} = 60t$ C4,C5 at $E_{max} = 75t$	$R_0$	1,010 ±1	1,010 ±1	1,010 ±1	1,010 ±1	$\Omega$		
			760 ±1	760 ±1	760 ±1	760 ±1	$\Omega$		
			635 ±1	635 ±1	635 ±1	635 ±1	$\Omega$		
			510 ±1	510 ±1	510 ±1	510 ±1	$\Omega$		
Insulation impedance	between measuring circuit and housing at 100V <sub>DC</sub>	$R_{IS}$	>5,000	>5,000	>5,000	>5,000	M $\Omega$		
Insulation voltage	between circuit and housing		500	500	500	500	V <sub>DC</sub>		
Recommended supply voltage	to hold the specified performance	$B_u$	4 ...24	4 ...24	4 ...24	4 ...24	V		
Max. supply voltage	permissible for continuous operation without damage	$U_{max}$	32	32	32	32	V		
Nominal ambient temp. range	to hold the specified performance	$B_T$	-10 ...+55	-10 ...+55	-10 ...+55	-10 ...+55	°C		
Usable ambient temp. range	permissible for continuous operation without damage	$B_{Tu}$	-40 ...+95	-40 ...+95	-40 ...+95	-40 ...+95	°C		
Storage temperature range	transportation and storage	$B_{Ti}$	-40 ...+95	-40 ...+95	-40 ...+95	-40 ...+95	°C		
Permissible eccentricity	permissible displacement from nominal load line	$S_{ex}$	10	10	10	10	mm		
Vibration resistance	resistance against oscillation (IEC68-2-6 Fc)		20g,100h, 10 ...150Hz	20g,100h, 10 ...150Hz	20g,100h, 10 ...150Hz	20g,100h, 10 ...150Hz			
Air pressure effect	influence of ambient air pressure on $S_{min}$	$PK_{S_{min}}$	<500	<500	<500	<500	g/kPa		

\*)  $E_{max} = 20t, 25t$  and  $30t$ ,  
Definitions acc. to VDI/VDE 2637.

The technical data given here serve only as a product description and must not be interpreted as guaranteed characteristics in the legal sense.

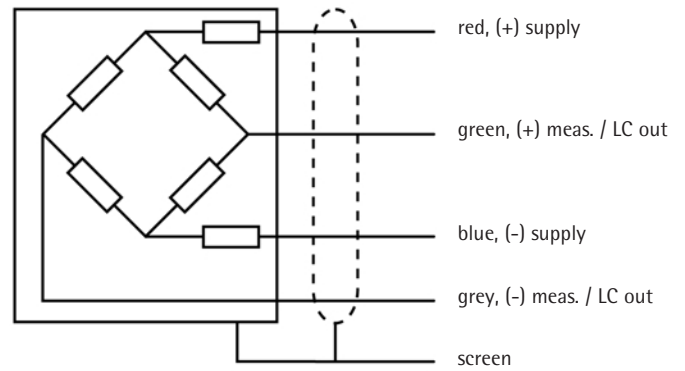
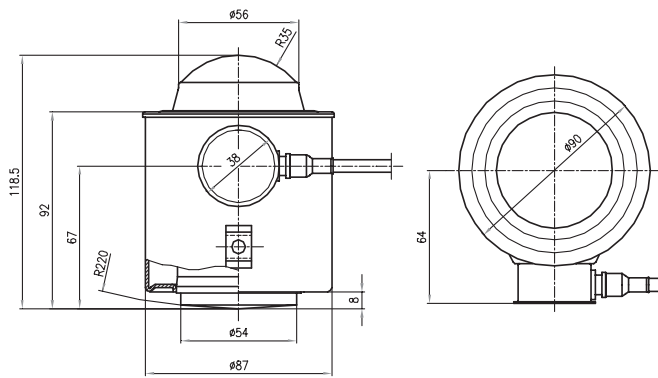

Dimensions in mm

#### Restoring force

For each mm of movement that the top of the load cell shifts from the vertical axis, a horizontal restoring force of 1.55 % of the applied vertical load is generated.

#### Load cell housing construction

Deep draw pulled housing, membrane and measuring element hermetically sealed, welded, filled with inert gas,

#### Material-Nr.

1.4301 (DIN 17440),304 S15 (B.S.)

#### Ingress Protection

IP 68, IEC 529 /EN 60529: 1.5 m water column /10,000 h  
IP 69K, DIN 40 050: water under high pressure, steam cleaning  
Sealing equivalent to NEMA 6

#### Cable

robust, flexible, screened,  
sheath: TPE,  
colour: green (for PR 6221/..E: colour: blue),  
diameter: 5 mm, 4 x AWG22 (0.35 mm<sup>2</sup>),  
length: 16 m

#### Bending radius

Fixed installation:  $\geq 50$ mm  
Flexible installation:  $\geq 150$ mm

#### Certificate of conformity

Feature:  
II 1G EEx ia IIC T6, II 1D IP65 T85 °C  
Registration number:  
PTB 02 ATEX 2059, TÜV 03 ATEX 2301x

#### Order information

Type	Nominal load $E_{max}$	Version	Max. usable load $E_{max}$ (in % of $E_{max}$ )	Destructive load (in % of $E_{max}$ )
PR6221/20t	20t	C3/C4/C5/C6 C3E/C4E/C5E/C6E	200	> 500
PR6221/25t	25t	C3/C4/C5/C6 C3E/C4E/C5E/C6E	150	> 300
PR6221/30t	30t	C3/C4/C5/C6 C3E/C4E/C5E/C6E	200	> 500
PR6221/50t	50t	C3/C4/C5 C3E/C4E/C5E	150	> 300
PR6221/60t	60t	C3/C4/C5 C3E/C4E/C5E	125	> 250
PR6221/75t	75t	C3/C4/C5 C3E/C4E/C5E	100	> 200

For professional applications further options and a wide range of additional mounting kits are available:

Type	Accessories	Order Number
PR6021/00N	Load and bottom disc Set of top and bottom load disc, tool steel, zinc plated, yellow chromated	9405 360 21001
PR6021/01N	Mounting Kit for PR 6221, including top and bottom load disc, zinc plated	9405 360 21011
PR6021/08	Cable Junction Box Plastic cable junction box for PR 6221, including lightning protection circuit	9405 360 21081
PR6021/68	Cable Junction Box Ex S/S cable junction box for PR 6221 for the use in EEx i circuits in hazardous area Zone 1, 2 and 0	9405 360 21682

PR 6021/01N, Mounting kit, complete

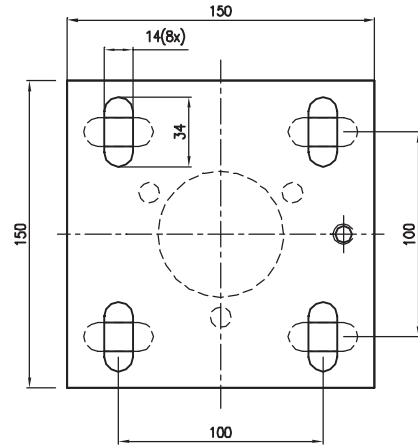
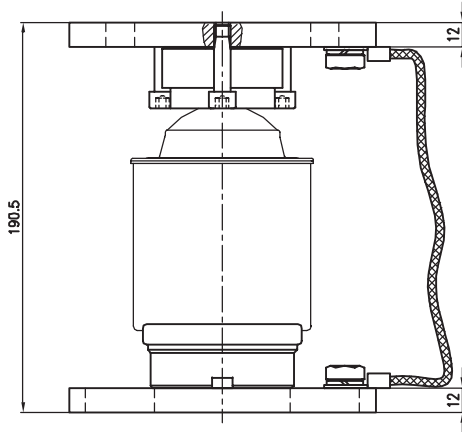

\*

\*

PR 6021/00N, Top and bottom load disc incl. rubber ring and earthing strap

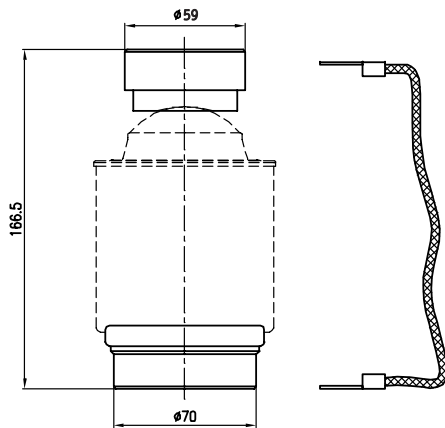

\*

\*

Cable junction box

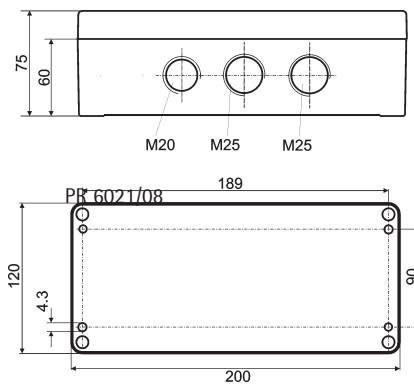
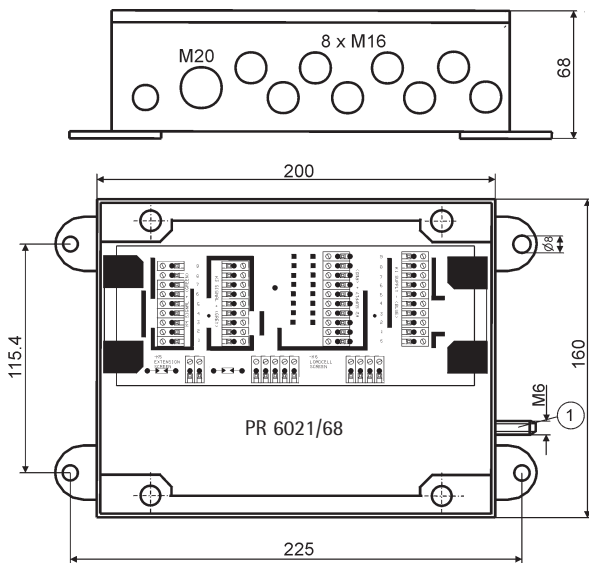

\*

\*

\* Dimensions in mm

Specifications subject to change without notice.  
Printed in Germany.  
n/sart • C  
9498 762 21001  
Version 03.2007

Sartorius Hamburg GmbH  
Meiendorfer Straße 205  
22145 Hamburg, Germany  
Tel. +49.40.67960.303  
Fax +49.40.67960.383  
www.sartorius.com